

0.75-3T

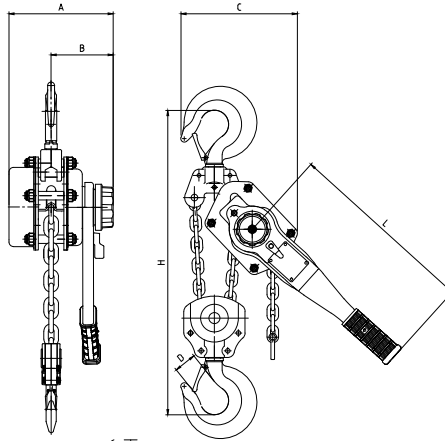

6T

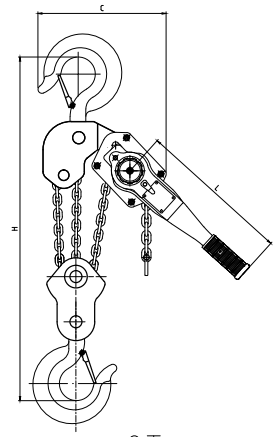

9T

Specifications

Model	Capacity (T)	Standard lift (m)	Running test (KN)	Effort required to lift max load (N)	No. of falls of load chain	Specification of load chain (mm)	Dimension(mm)						Net weight (kg)
							A	B	C	D	H	L	
JTVPG-K 0.75	0.75	1.5	11.25	210	1	6×18	151	91	135	32	320	245	7
JTVPG-K 1	1	1.5	15	250	1	6×18	151	91	135	32	320	245	7
JTVPG-K 1.5	1.5	1.5	22.5	240	1	8×24	179	105	155	36	380	415	11
JTVPG-K 2	2	1.5	30	280	1	8×24	179	105	155	36	380	415	11
JTVPG-K 3	3	1.5	45	320	1	10×30	195	109	211	41	480	415	19
JTVPG-K 6	6	1.5	90	340	2	10×30	195	109	254	46	600	415	32
JTVPG-K 9	9	1.5	135	360	3	10×30	195	109	319	60	700	415	47